

BIDS AND AWARDS COMMITTEE
2330 Roxas Boulevard, Pasay City
Tel. Nos. 834-4823; Fax No. 831-9584
Email: bac.secretariat@dfa.gov.ph

SUPPLEMENTAL / BID BULLETIN No. 1

Project : Human Resource Management Office Furniture
Reference No.: PB-GS-08-2017
ABC : PhP 1,999,894.00
Date : 13 October 2017

This supplemental/bid bulletin is issued to provide information to the prospective proponents/bidders on the following changes to the Bidding Documents:

I. Technical Specifications (Section VII)

The Technical Specifications (Section VII) of the Bidding Documents is superseded by this Supplemental/Bid Bulletin No. 1.

The Bidding Documents is amended accordingly.



For the information and guidance of all concerned.

(Sgd.)

MARIA TERESA C. LEPATAN
BAC Chairperson

Technical Specifications

OFFICE FURNITURE

I	BACKGROUND <p>The Department of Foreign Affairs intends to procure brand new furnishings for the Human Resource Management Office and its conference rooms.</p>						
II	OBJECTIVE <p>To furnish office chairs for officers and staff, conference chairs for two (2) conference rooms, lounge chairs and visitor's chairs for the Human Resource Management Office.</p>						
III	SPECIFICATIONS	Photo/Measurement	Statement of Compliance				
	<table border="1" style="width: 100%; border-collapse: collapse;"> <thead> <tr> <th style="width: 10%;">Qty</th> <th style="width: 90%;">Executive Chairs</th> </tr> </thead> <tbody> <tr> <td></td> <td> <ul style="list-style-type: none"> Color: black Executive Chair High Back With adjustable headrest Heavy Duty (can carry a weight of 250 lbs. and above) High quality and durable Ergonomic and with adjustable lumbar support Back – in nylon Mesh Seat – 70mm thick injected foam with net cover Height Adjustable Armrest Synchronous Mechanism with tension adjustment Lockable tilt in any position Pneumatic Seat Height Adjustment (Gas lift) High legged nylon base Passed BIFMA standards Dimension (as shown in the Photo/Measurement) <p><i>Note: High-legged base refers to the executive chair's base design. While executive chair base is usually parallel to the flooring, (see image 1) the high-legged base's center has a higher elevation from the floor than the tip of the legs (see image 2). It is slightly cone-shaped.</i></p> </td> </tr> </tbody> </table>	Qty	Executive Chairs		<ul style="list-style-type: none"> Color: black Executive Chair High Back With adjustable headrest Heavy Duty (can carry a weight of 250 lbs. and above) High quality and durable Ergonomic and with adjustable lumbar support Back – in nylon Mesh Seat – 70mm thick injected foam with net cover Height Adjustable Armrest Synchronous Mechanism with tension adjustment Lockable tilt in any position Pneumatic Seat Height Adjustment (Gas lift) High legged nylon base Passed BIFMA standards Dimension (as shown in the Photo/Measurement) <p><i>Note: High-legged base refers to the executive chair's base design. While executive chair base is usually parallel to the flooring, (see image 1) the high-legged base's center has a higher elevation from the floor than the tip of the legs (see image 2). It is slightly cone-shaped.</i></p>	  Image 1  Image 2	
Qty	Executive Chairs						
	<ul style="list-style-type: none"> Color: black Executive Chair High Back With adjustable headrest Heavy Duty (can carry a weight of 250 lbs. and above) High quality and durable Ergonomic and with adjustable lumbar support Back – in nylon Mesh Seat – 70mm thick injected foam with net cover Height Adjustable Armrest Synchronous Mechanism with tension adjustment Lockable tilt in any position Pneumatic Seat Height Adjustment (Gas lift) High legged nylon base Passed BIFMA standards Dimension (as shown in the Photo/Measurement) <p><i>Note: High-legged base refers to the executive chair's base design. While executive chair base is usually parallel to the flooring, (see image 1) the high-legged base's center has a higher elevation from the floor than the tip of the legs (see image 2). It is slightly cone-shaped.</i></p>						

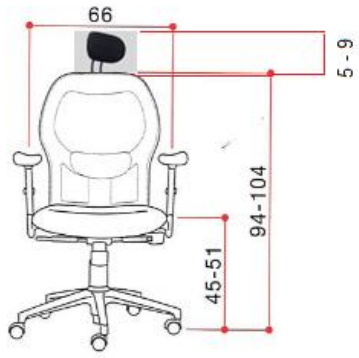

(cm)



DIMENSION (



36 pcs.



Conference Chair without Armrest



- Color: black
- Back - Mesh backrest
- Seat in crepe fabric with 50mm thick molded fire retardant foam
- Tilt Mechanism with Adjustable Tension Control
- Pneumatic Seat Height Adjustment
- Ergonomically designed
- 650mm Nylon 5-star base tested and passed 1300 kg.
- With Adjustable Lumbar Support
- High quality and durable

Note: The 650mm Nylon 5-Star base should have been tested and passed 1300 kg, which does not refer to the weight load capacity. For its weight load capacity, the conference chair must be able to carry a weight of 125-150 kg.



Note:
Same dimension as above without armrest.

	<p>24 pcs.</p>	<p style="text-align: center;">Visitor's Chair</p> <ul style="list-style-type: none"> • Color: black • Ergonomically designed 2-piece wood shell • With armrests • With back and seat fabric upholstery • Powder-coated cantilever base • High quality and durable 		
	<p>14 pcs.</p>	<p style="text-align: center;">Lounge Chair</p> <ul style="list-style-type: none"> • Color: 10 pieces black, 4 pieces orange • Single seater chair • Fabric, thick foam and plywood • 63 (w) x 65 (D) x 87 (H) • Steel frame and chrome legs • With velvet upholstery • High quality and durable 		

	4 pcs.	<p style="text-align: center;">Working Chair</p> <ul style="list-style-type: none"> • Color: black • Metal back frame • Plywood • Sponge • Leatherette upholstery • Chrome supporting frame • Chrome cantilever base • High quality and durable • Dimension: 60 (w) x 60 (d) x 78 (h) cm 		
	1 set (Base & Glass)	<p style="text-align: center;">Working Table</p> <ul style="list-style-type: none"> • 90 cm in diameter x 72 9H) cm • 10 mm tempered clear glass table top • Chrome base • High quality and durable 		
	3 sets (Base & Glass)	<p style="text-align: center;">Center Table</p> <ul style="list-style-type: none"> • Rectangular center table • 120-135 (W) x 70-75 (D) x 42 (H) cm • 10 mm tempered clear glass table top • Stainless steel base • High quality and durable 		

	2 sets (Base & Glass)	<p style="text-align: center;">Side Table</p> <ul style="list-style-type: none"> • Square side table • 70-75 (W) x 70-75 (D) x 42-45 (H) cm • 10 mm tempered clear glass table top • Stainless steel base • High quality and durable 		
IV	<p>SUPPLIER RESPONSIBILITY/CONDITIONS</p> <ol style="list-style-type: none"> a. The Supplier/Bidder must supply the above items in conformity with the specifications and measurements provided above. b. As part of Post Qualification, the Supplier/Bidder must bring the actual models of each item (chairs and tables) for inspection, testing and approval. c. The Supplier/Bidder shall provide a warranty period of at least two (2) years for all the items. A certificate of the warranty must be presented during the Post Qualification. d. An item/s found with any factory defect and not properly functioning must be replaced within seven days and a service unit shall be provided until delivery of the replacement. e. All items shall be priced below Fifteen Thousand Pesos (Php15,000.00) per unit. f. The Supplier/Bidder must have been engaged in the business for at least five (5) years. 			
V	<p>PAYMENT</p> <p>The Procuring Entity shall pay the Supplier/Provider within thirty (30) working days from the receipt of the invoice with complete requirements through List of Due and Demandable Accounts Payable (LDDAP).</p> <p>The list of documentary requirements needed for payment will be provided by the Office of Financial Management Services-Financial Resource Management Division (OFMS-FRMD) upon signing of the contract</p> <p>All payments shall be inclusive of Value-Added Tax (VAT) and other lawful government charges.</p>			
VI	<p>DELIVERY</p> <p>Delivery shall be made within forty-five (45) days from the receipt of the Notice to Proceed.</p>			

Note:

Bidder must state compliance to each of the provisions in the Terms of Reference/Technical Specifications, as well as to the Schedule of Requirements. The Statement of Compliance must be signed by the authorized representative of the Bidder, with proof of authority to sign and submit the bid for and in behalf of the Bidder concerned. If the Bidder is a joint venture, the representative must have authority to sign for and in behalf of the partners to the joint venture. All documentary requirements should be submitted on or before the deadline for the submission of bids.

Conformé:

[Signature/s]

[Name of the Bidder/ Bidder's Authorized Representative/s]

[Position]

[Date]