



DEPARTMENT OF FOREIGN AFFAIRS
KAGAWARAN NG UGNAYANG PANLABAS

BIDS AND AWARDS COMMITTEE
2330 Roxas Boulevard, Pasay City
Tel. Nos.: 834-4823; Fax No.: 831-9584
Email: bac.secretariat@cfa.gov.ph

SUPPLEMENTAL / BID BULLETIN NO. 1

Project : Procurement for the Repair, Operation and Maintenance of Sewage Treatment Plant of DFA OCA Aseana from January-December 2024
Reference : PB-GS-23-2023-EP8
ABC : PhP 1,500,000.00
Date : 26 October 2023

This Supplemental/Bid Bulletin is being issued to provide prospective bidders additional information on the Technical Specifications of this procurement project:

1. Item III. Scope of Work. Deployment of personnel and the corresponding duties and obligations.

The contractor shall:

xxx

"Provide sub-meters for measuring electrical consumption by the Contractor. The Contractor and OAMSS-EMD shall conduct a monthly joint reading of the sub-meter and OFMS of the DFA shall verify and prepare the electric bill the contractor will pay for the actual consumption of electricity at the DFA OCA Aseana."

The electricity bill to be shouldered by the contractor pertains to the electric consumption of the contractor's electric tools and equipment during repair and maintenance. This electricity bill shall not include the operation of the Sewage Treatment Plant (STP).

2. As a background for this project, the STP was upgraded and rehabilitated in 2018.

3. Item IV. Site Inspection. Prospective bidders are requested to coordinate with the Office of Asset and Management and Support Services- Engineering, Maintenance Division (OAMSS-EMD) to arrange a schedule of the site visit. The contact person of OAMSS-EMD is Engr. Jomar S. Banguilan, with contact number +63977-465-7179 or (02) 8834-4362, or through email at jomar.banguilan@dfa.gov.ph.

Bidders are reminded that the Certificate of Site Inspection is a requirement during the opening of bids.

4. Annexes A and B are attached, for reference.

For the information and guidance of all concerned.

SULPICIO M. CONFIA DO

Assistant Secretary and BAC Chairperson

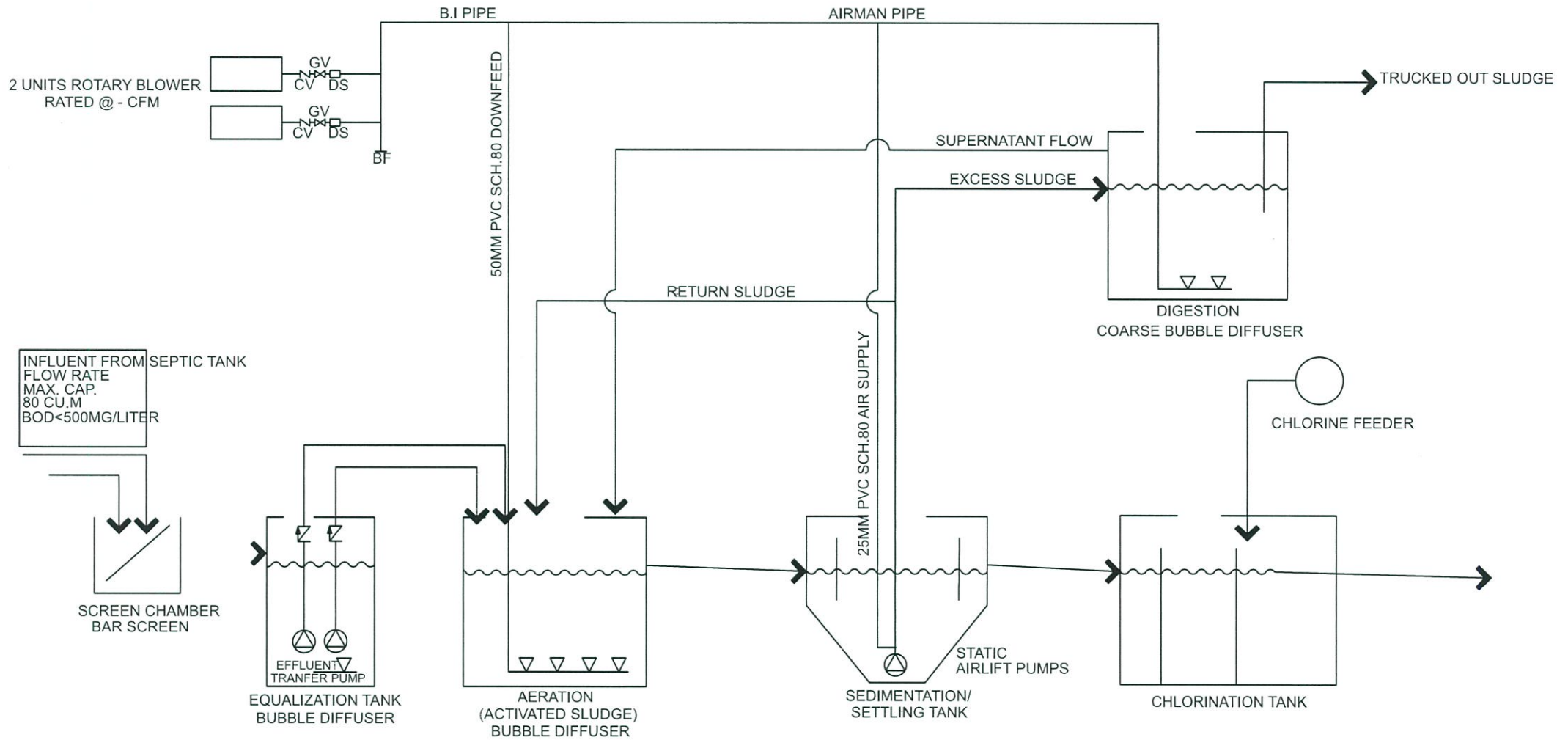

PROCESS FLOW DIAGRAM

ANNEX B. BID OFFER FORM

OPERATION AND PREVENTIVE MAINTENANCE FOR DFA OCA-ASEANA 2024

SCOPE OF WORKS					
	Schedule	Quantity	UNIT	Unit Cost	Total Unit Cost
MANPOWER OPERATOR (3 shift, 8hr/shift or 2 shift, 12hr/shift)	7 days/week	12	Months		
Engineer/Technical Personnel's Site visit and inspection of STP equipment and facility	Monthly	12	Months		
Equipment (Pumps)	/				
Electrical Components	/				
Motor Control Panel	/				
Waste water effluent for laboratory analysis	Quarterly	4	Quarterly		
Biological Oxygen Demand	/				
Chemical Oxygen Demand	/				
Total Suspended Solid	/				
Oil and Grease	/				
pH	/				
Color	/				
Fecal Coliform	/				
Nitrates	/				
Ammonia	/				
Phosphates	/				
Surfactants (MBAS)	/				
Submission of reports (Self Monitoring Report)	Monthly	12	Months		
Supply of chemicals	Monthly	12	Monthly		
Chlorine Granules	/				
Chlorine Test Kits	/				
pH Test Kits	/				
Cleaning Supplies	/				
Supply and Installation of Chlorinator	1st Month	1	Unit		
Siphoning and Disludging of Septic Tank (10 Cu.m)	1st Quarter	1	Lot		
Miscellaneous	Monthly	1	lot		
<i>Note: Please see details in Term of Reference</i>					
OVERALL TOTAL AMOUNT					